

Pipelining

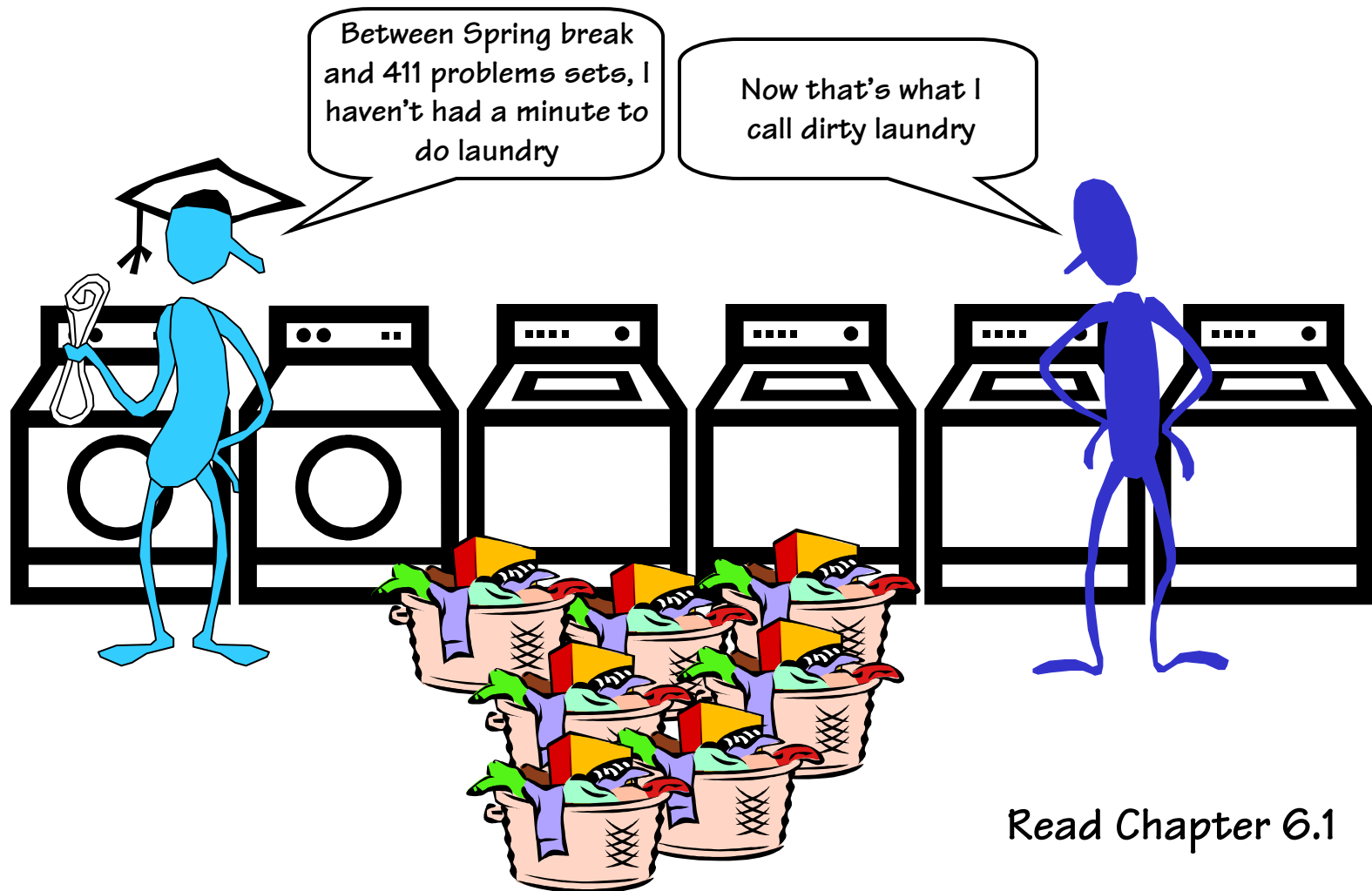

Forget 411... Let's Solve a "Relevant Problem"

INPUT:
dirty laundry



OUTPUT:
4 more weeks



Device: Washer

Function: Fill, Agitate, Spin

Washer_{PD} = 30 mins

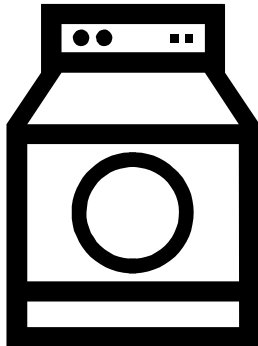

Device: Dryer

Function: Heat, Spin

Dryer_{PD} = 60 mins

One Load at a Time

Everyone knows that the real reason that UNC students put off doing laundry so long is **not** because they procrastinate, are lazy, or even have better things to do.

The fact is, doing laundry one load at a time is not smart.

(Sorry Mom, but you were wrong about this one!)

Step 1:

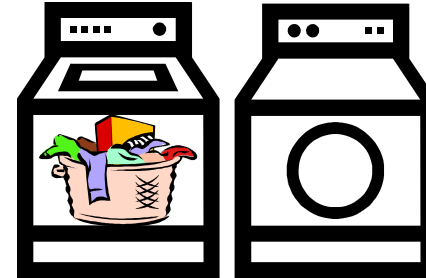

Step 2:

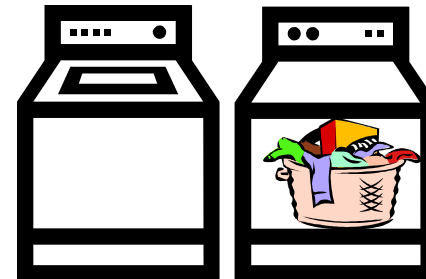

$$\begin{aligned} \text{Total} &= \text{Washer}_{PD} + \text{Dryer}_{PD} \\ &= \underline{\quad 90 \quad} \text{ mins} \end{aligned}$$

Doing N Loads of Laundry

Here's how they do laundry at Duke, the "combinational" way.

(Actually, this is just an urban legend. No one at Duke actually does laundry. The butler's all arrive on Wednesday morning, pick up the dirty laundry and return it all pressed and starched by dinner)

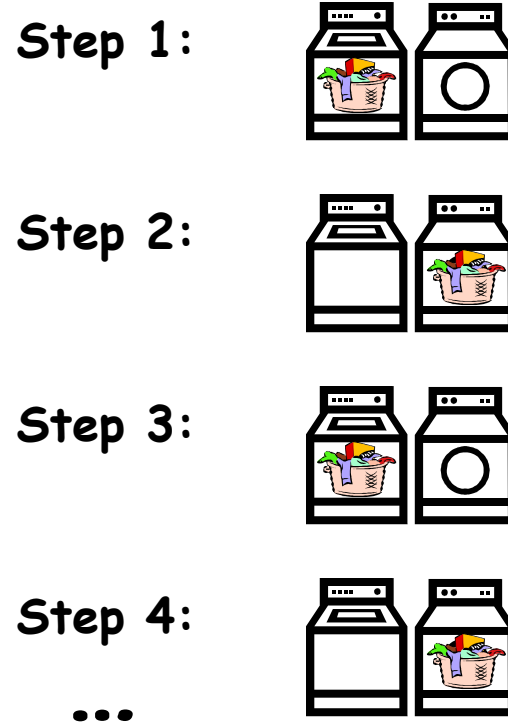

$$\begin{aligned} \text{Total} &= N * (\text{Washer}_{PD} + \text{Dryer}_{PD}) \\ &= \underline{\quad N * 90 \quad} \text{ mins} \end{aligned}$$

Doing N Loads... the UNC way

UNC students “pipeline”
the laundry process.

That’s why we wait!

Actually, it’s more like $N*60 + 30$ if we account for the startup transient correctly. When doing pipeline analysis, we’re mostly interested in the “steady state” where we assume we have an infinite supply of inputs.

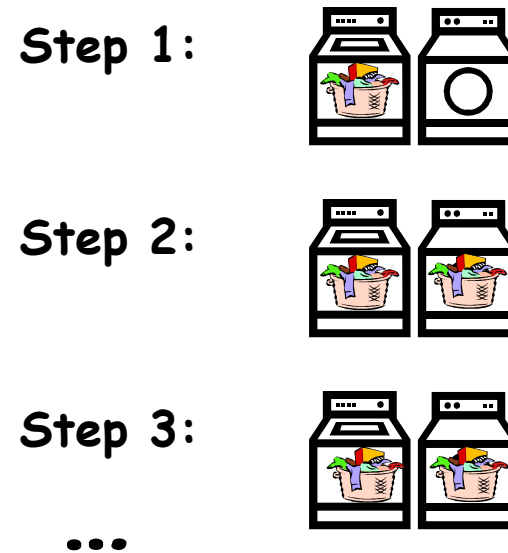

$$\begin{aligned} \text{Total} &= N * \text{Max}(\text{Washer}_{PD}, \text{Dryer}_{PD}) \\ &= \underline{\quad N*60 \quad} \text{ mins} \end{aligned}$$

Recall Our Performance Measures

Latency:

The delay from when an input is established until the output associated with that input becomes valid.

(Duke Laundry = $\frac{90}{\quad}$ mins)

(UNC Laundry = $\frac{120}{\quad}$ mins)

← Assuming that the wash is started as soon as possible and waits (wet) in the washer until dryer is available.

Throughput:

The rate of which inputs or outputs are processed.

(Duke Laundry = $\frac{1/90}{\quad}$ outputs/min)

(UNC Laundry = $\frac{1/60}{\quad}$ outputs/min)



Even though we increase latency, it takes less time per load

Okay, Back to Circuits...

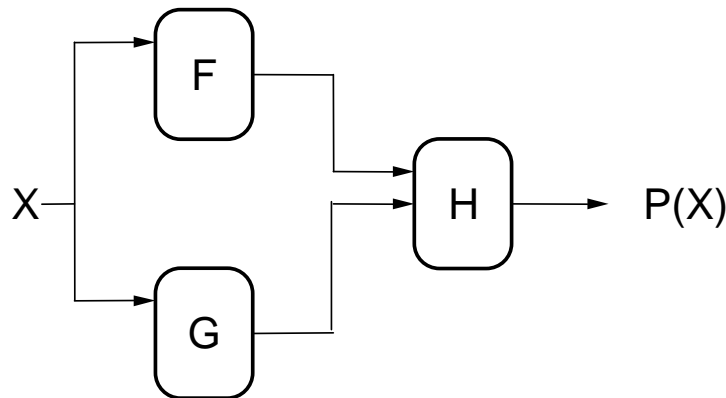

For combinational logic:

$$\text{latency} = t_{PD},$$

$$\text{throughput} = 1/t_{PD}.$$

We can't get the answer faster, but are we making effective use of our hardware at all times?

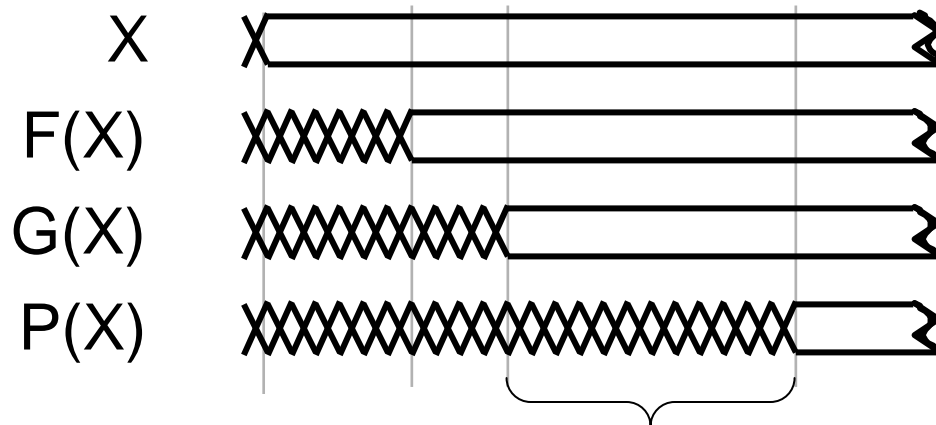

F & G are "idle", just holding their outputs stable while H performs its computation

Pipelined Circuits



use registers to hold H's input stable!

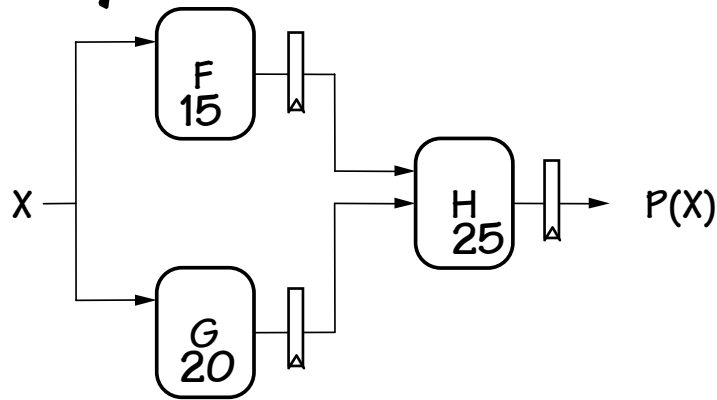

Now F & G can be working on input X_{i+1} while H is performing its computation on X_i . We've created a 2-stage *pipeline*: if we have a valid input X during clock cycle j, P(X) is valid during clock j+2.

Suppose F, G, H have propagation delays of 15, 20, 25 ns and we are using *ideal zero-delay registers* ($t_s = 0, t_{pd} = 0$):

	<u>latency</u>	<u>throughput</u>
unpipelined	45	1/45
2-stage pipeline	50	1/25

worse



better



Pipelining uses registers to improve the throughput of combinational circuits

Pipeline Diagrams

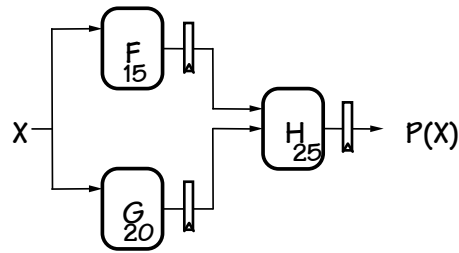

Pipeline stages

Clock cycle

	i	$i+1$	$i+2$	$i+3$	
Input	X_i	X_{i+1}	X_{i+2}	X_{i+3}	...
F Reg		$F(X_i)$	$F(X_{i+1})$	$F(X_{i+2})$...
G Reg		$G(X_i)$	$G(X_{i+1})$	$G(X_{i+2})$...
H Reg			$H(X_i)$	$H(X_{i+1})$	$H(X_{i+2})$

This is an example of parallelism. At any instant we are computing 2 results.

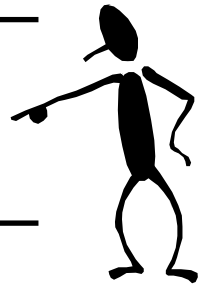

The results associated with a particular set of input data moves *diagonally* through the diagram, progressing through one pipeline stage each clock cycle.

Pipeline Conventions

DEFINITION:

a *K-Stage Pipeline* (“K-pipeline”) is an acyclic circuit having exactly K registers on every path from an input to an output.

a COMBINATIONAL CIRCUIT is thus a 0-stage pipeline.

CONVENTION:

Every pipeline stage, hence every K-Stage pipeline, has a register on its *OUTPUT* (not on its input).

ALWAYS:

The CLOCK common to all registers *must* have a period sufficient to allow for the propagation delays of all combinational paths PLUS (input) register t_{PD} PLUS (output) register t_{SETUP} .

The LATENCY of a K-pipeline is K times the period of the clock common to all registers.

The THROUGHPUT of a K-pipeline is the frequency of the clock.

Ill-Formed Pipelines

Consider a BAD job of pipelining:

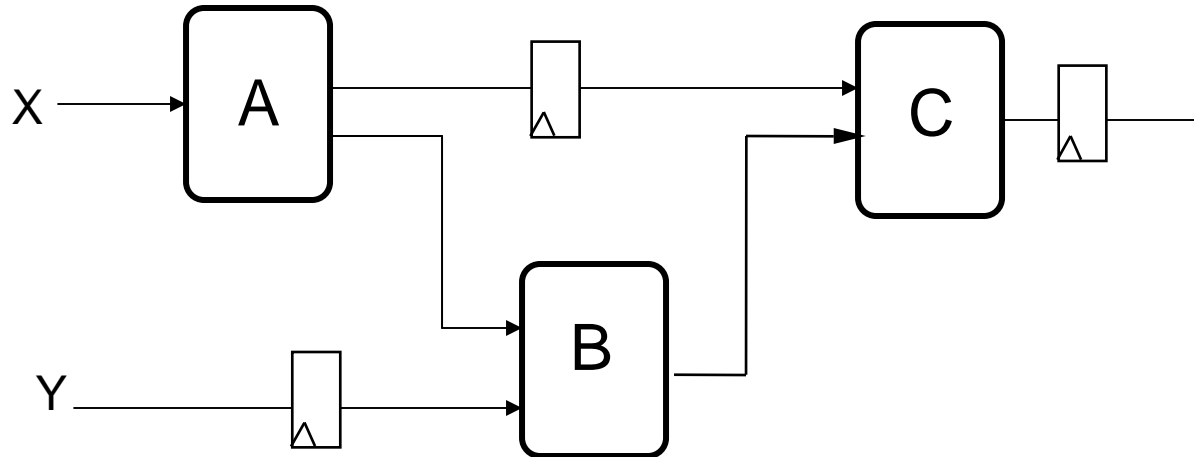

For what value of K is the following circuit a K-Pipeline? ANS: none

Problem:

Successive inputs get mixed: e.g., $B(A(X_{i+1}), Y_i)$. This happened because some paths from inputs to outputs had 2 registers, and some had only 1!

Can this happen on a well-formed K pipeline?

A Pipelining Methodology

Step 1:

Draw a line that *crosses every output* in the circuit, and *select one endpoint* as an origin.

Step 2:

Continue to draw new lines from the origin *across various circuit connections* such that these new lines partition the inputs from the outputs.

Adding a pipeline register at every point where a separating line crosses a connection will always generate a valid pipeline.

STRATEGY:

Focus your attention on placing pipelining registers around the *slowest circuit elements (BOTTLENECKS)*.

In these examples we assume “idealized” pipeline registers, with $t_{pd} = 0$ and $t_s = 0$.

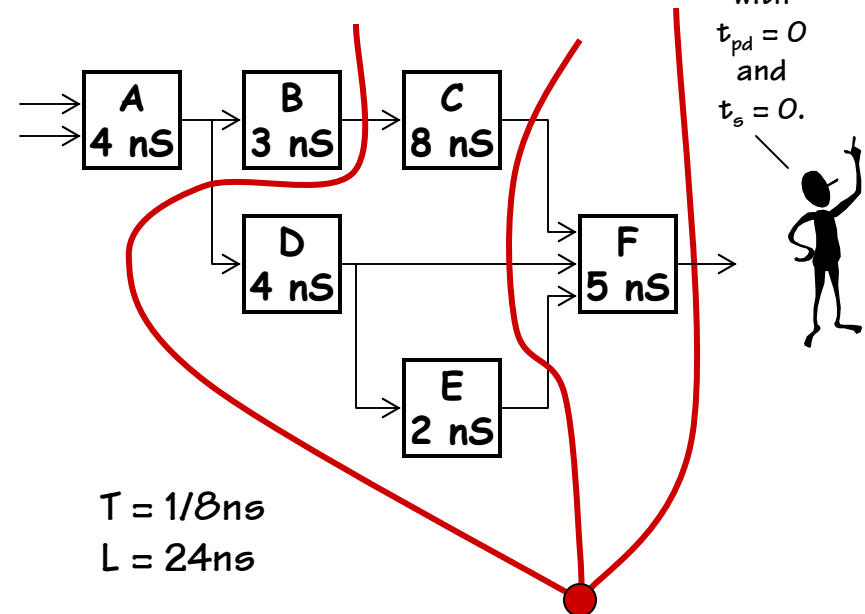

Extreme Pipelining

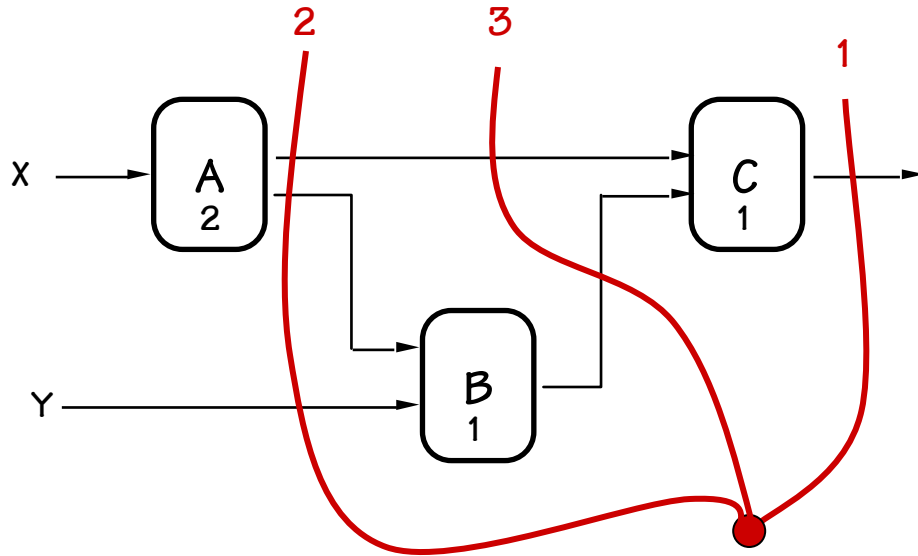

OBSERVATIONS:

- 1-pipeline improves neither L or T.
- T improved by breaking long combinational paths, allowing faster clock.
- Too many stages cost L, don't improve T.
- Back-to-back registers are often required to keep pipeline well-formed.

	LATENCY	THROUGHPUT
0-pipe:	4	1/4
1-pipe:	4	1/4
2-pipe:	4	1/2
3-pipe:	6	1/2

Pipelining Summary

Advantages:

- Higher throughput than combinational system
- Different parts of the logic work on different parts of the problem...

Disadvantages:

- Generally, increases latency
- Only as good as the **weakest** link
(often called the pipeline's BOTTLENECK)

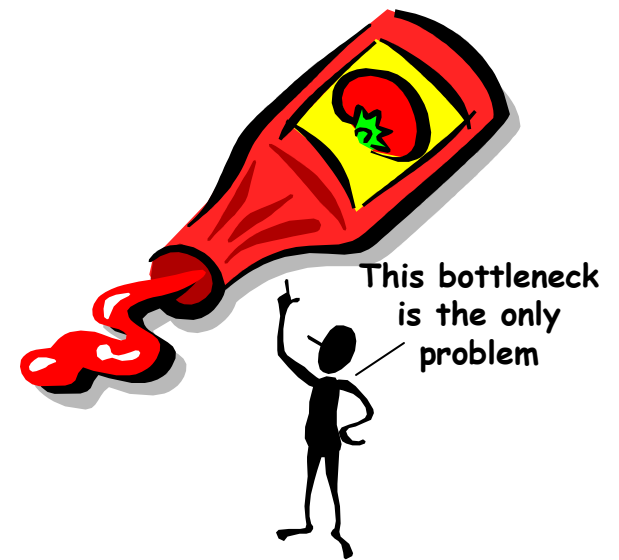

Isn't there a way around this "weak link" problem?

How do UNC students REALLY do Laundry?

They work around the bottleneck.
First, they find a place with
twice as many dryers as
washers.

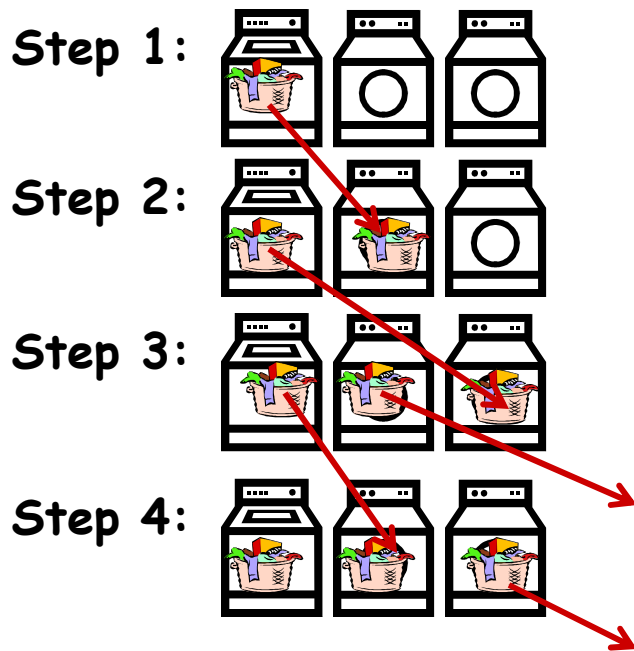

$$\text{Throughput} = \frac{1}{30} \text{ loads/min}$$

$$\text{Latency} = \underline{90} \text{ mins/load}$$

Circuit Interleaving

One way to overcome a pipeline bottleneck is to replicate the critical element as many times as needed and alternate inputs between the various copies.

N-way interleaving is equivalent to how many pipeline Stages? N

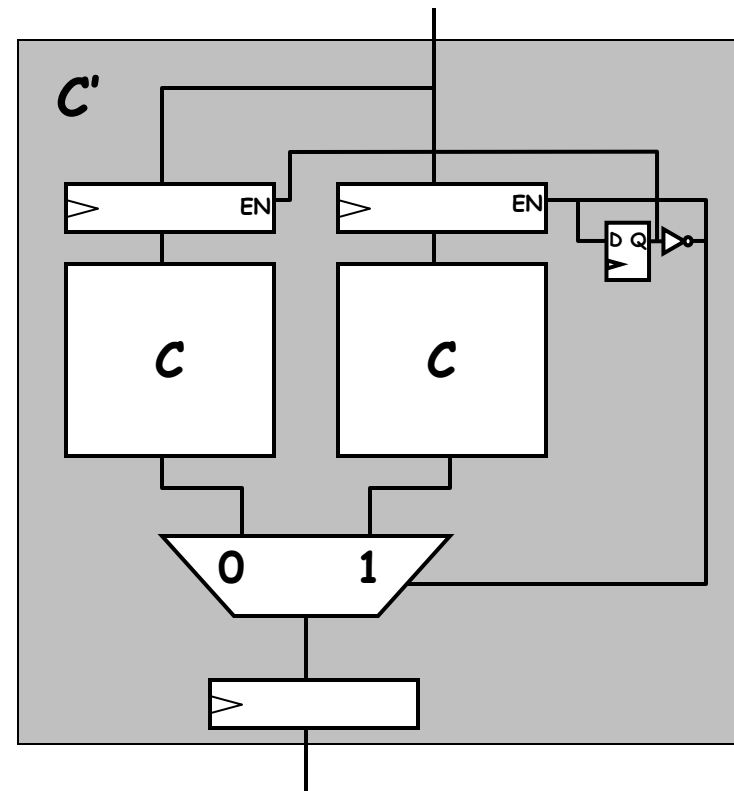
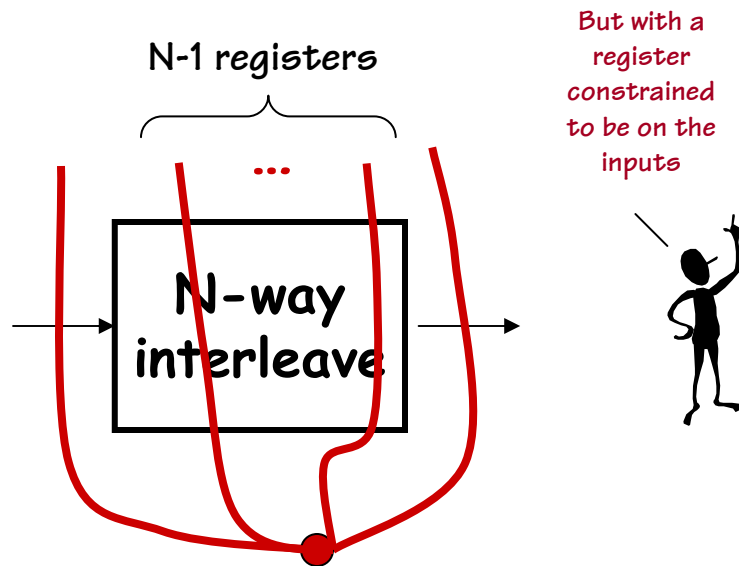

Latency = 2 clocks

Combining Techniques

We can combine interleaving and pipelining. Here, C' interleaves two C elements with a propagation delay of 8 nS . The resulting C' circuit has a throughput of 4 nS , and latency of 8 nS . This can be considered as an extra pipelining stage that passes through the middle of the C' module. One of our separation lines must pass through this pipeline stage.

By combining interleaving with pipelining we move the bottleneck from the C element to the F element.

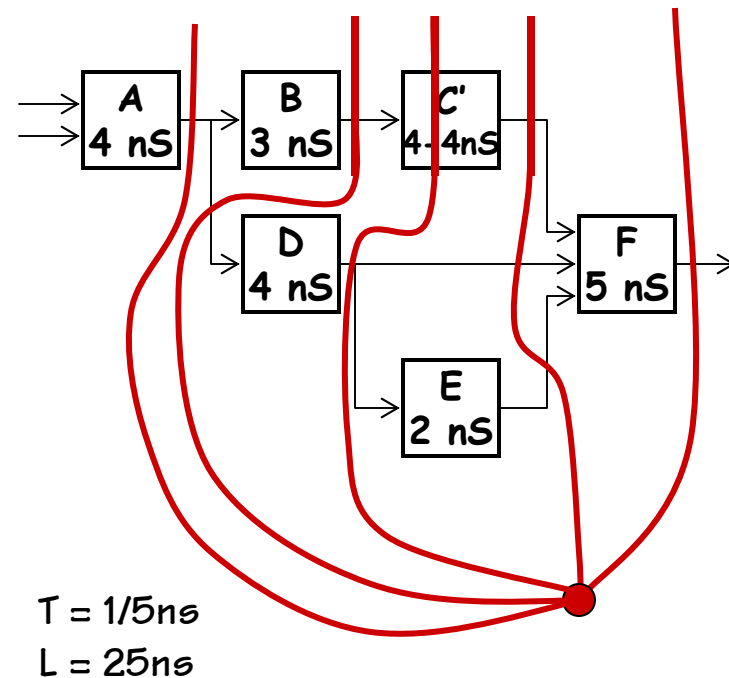

Better Yet... Parallelism

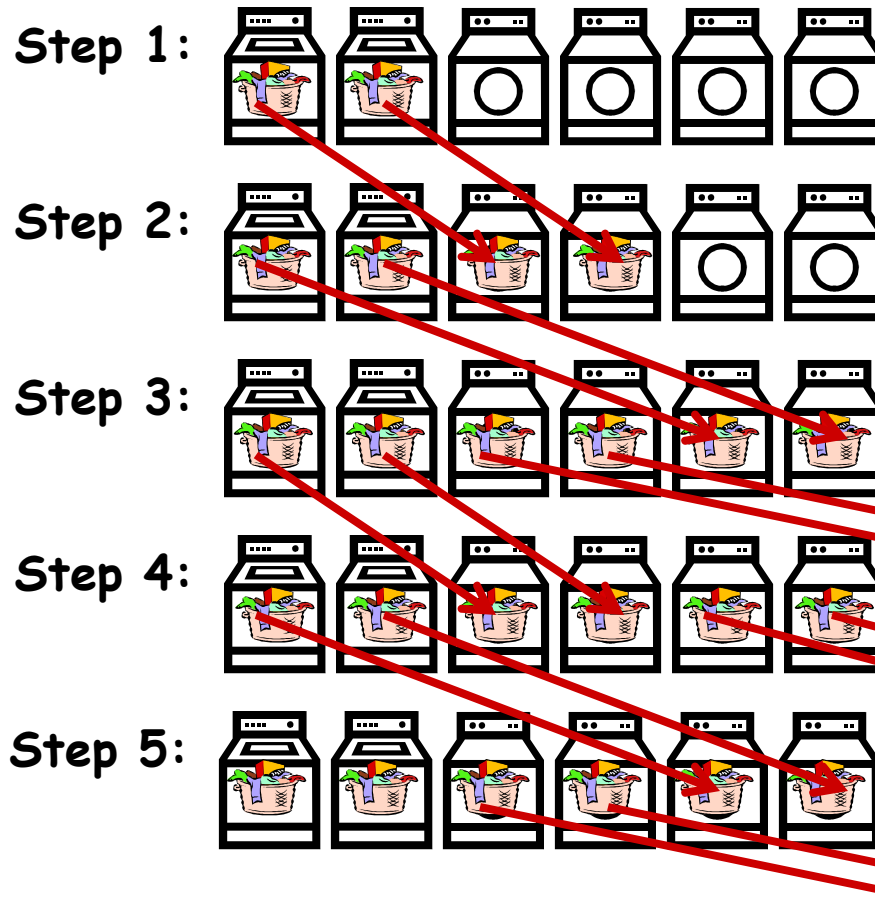

We can combine interleaving and pipelining with parallelism.

Throughput = $\frac{2}{30} = \underline{1/15}$ load/min

Latency = 90 min

Other Control Structure Approaches

Synchronous

ALL computation “events” occur at active edges of a periodic clock: time is divided into fixed-size discrete intervals.

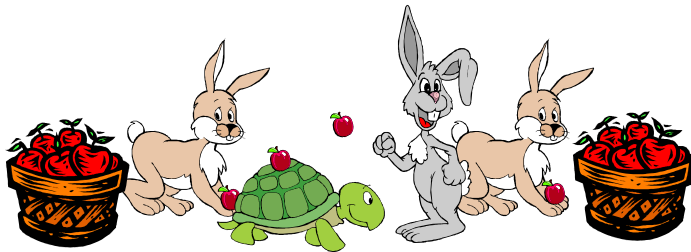

Asynchronous

Events – e.g. the loading of a register -- can happen at arbitrary times.

RIGID



Laid Back

Globally Timed

Timing dictated by centralized FSM according to a fixed schedule.



Locally Timed

Each module takes a START signal, generates a FINISHED signal. Timing is dynamic, data dependent.

"Classroom Computer"

There are lots of problem sets to grade, each with six problems. Students in Row 1 grade Problem 1 and then hand it back to Row 2 for grading Problem 2, and so on... Assuming we want to pipeline the grading, how do we time the passing of papers between rows?

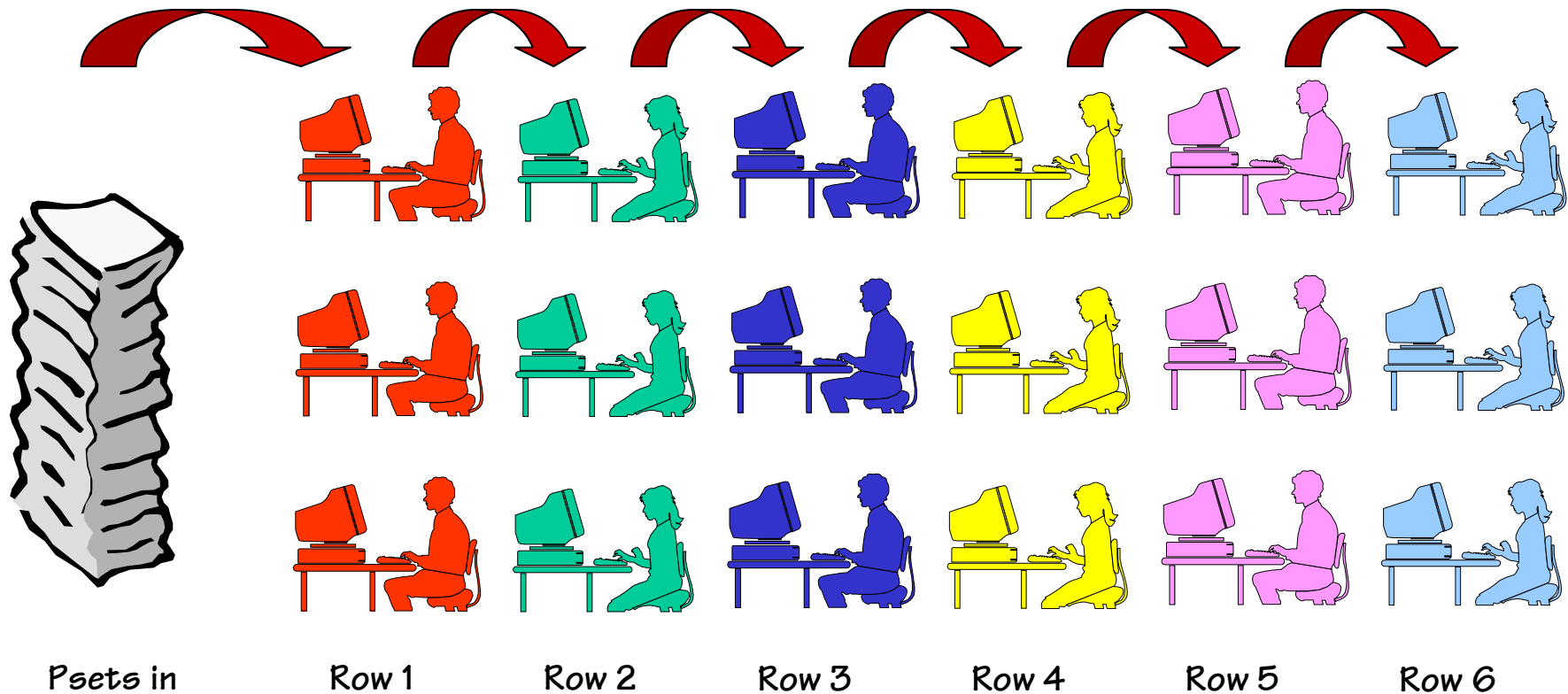

Controls for "Classroom Computer"

Synchronous

Asynchronous

Globally Timed

Teacher picks time interval long enough for worst-case student to grade toughest problem. Everyone passes psets at end of interval.

Teacher picks variable time interval long enough for current students to grade current set of problems. Everyone passes psets at end of interval.

Locally Timed

Students raise hands when they finish grading current problem. Teacher checks every 10 secs, when all hands are raised, everyone passes psets to the row behind. Variant: students can pass when all students in a "column" have hands raised.

Students grade current problem, wait for student in next row to be free, and then pass the pset back.

Control Structure Taxonomy

Easy to design but fixed-sized interval can be wasteful (no data-dependencies in timing)

Large systems lead to very complicated timing generators... just say no!

Synchronous

Asynchronous

Globally Timed

Centralized clocked FSM generates all control signals.

Central control unit tailors current time slice to current tasks.

Locally Timed

Start and Finish signals generated by each major subsystem, synchronously with global clock.

Each subsystem takes asynchronous Start, generates asynchronous Finish (perhaps using local clock).

The best way to build large systems that have independent components.

The "next big idea" for the last several decades: a lot of design work to do in general, but extra work is worth it in special cases

Summary

- **Latency (L)** = time it takes for the results from a given input to arrive at outputs
- **Throughput (T)** = rate at each new outputs appear
- For combinational circuits: $L = t_{PD}$ of circuit, $T = 1/L$
- For K-pipelines ($K > 0$):
 - always have register on output(s)
 - K registers on every path from input to output
 - $T = 1/(t_{PD,REG} + t_{PD}$ of slowest pipeline stage + $t_{SETUP})$
 - more throughput → split slowest pipeline stage(s)
 - use replication/interleaving if no further splits possible
 - $L = K / T$
 - pipelined latency \geq combinational latency