

Comp 411 Computer Organization

Fall 2009

Problem Set #5

Issued Wednesday, 10/28/09; Due Wednesday, 11/04/09 (beginning of class)

Note: You may use additional sheets of paper, but please enter your answers in the space provided in this document.

**Problem 1. Mux Madness (15 points)**

Suppose you wanted to implement a Boolean function  $Y$  of two inputs  $A$  and  $B$  using multiplexers, as shown in the figure.

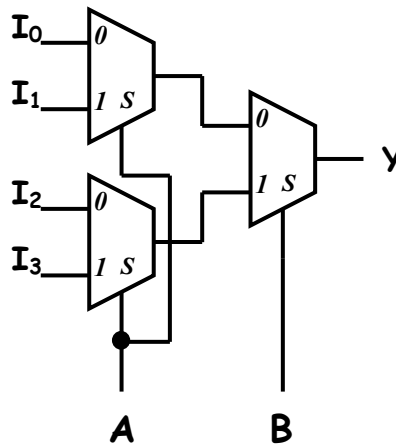

Give binary values for  $I_0$ ,  $I_1$ ,  $I_2$ , and  $I_3$  that implement the following functions on the two inputs  $A$  and  $B$ :

- a)  $Y = \text{XNOR}(A,B)$
- b)  $Y = (A \neq B)$
- c)  $Y = (A < B)$

**Problem 2. “Go Forth and Multiply” (30 points)**

- a) [15 points] Complete the truth table below showing multiplication of two 2-bit unsigned integers  $A_1A_0$  and  $B_1B_0$ , producing a 4-bit result  $P_3P_2P_1P_0$ . Please enter your answer directly in the table below.

$A_1A_0B_1B_0$	$P_3P_2P_1P_0$
0000	
0001	
0010	
0011	
0100	
0101	
0110	
0111	
1000	
1001	
1010	
1011	
1100	
1101	
1110	
1111	

- b) [15 points] Suppose you wanted to compute the cube (third power) of a 2-bit number. Complete the truth table below in which the input column contains the 2-bit input, and the output column is the 6-bit result.

$A_1A_0$	$P_5P_4P_3P_2P_1P_0$
00	
01	
10	
11	

For each of the 6 output bits, give the sum-of-products Boolean equation (circuit not needed):

- $P_0 =$   
 $P_1 =$   
 $P_2 =$   
 $P_3 =$   
 $P_4 =$   
 $P_5 =$

How many Boolean gates are needed for this implementation?

**Problem 3. “Fishing for Complements” (15 points).** Show the complementary set of p-channel or n-channel transistors that complete the following CMOS circuits:

a)

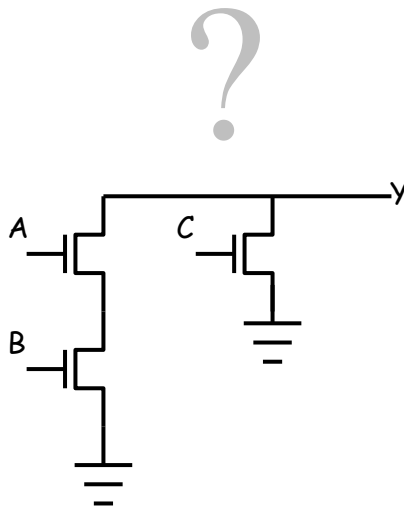

b)

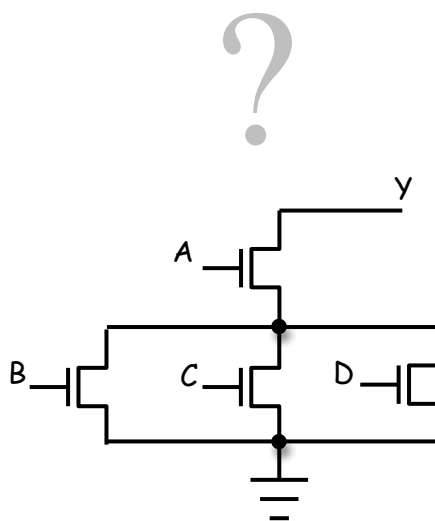

c)

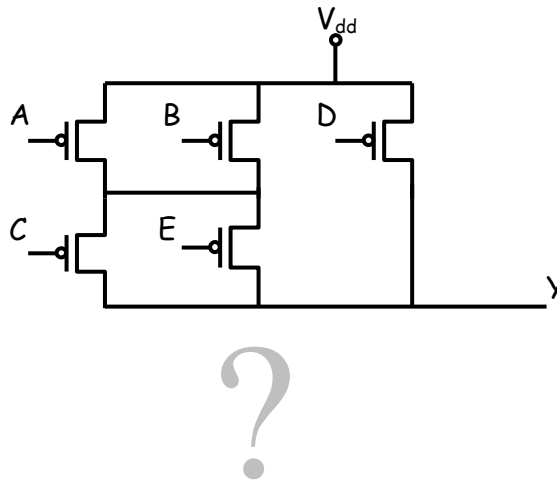

**Problem 4. “Bits of Floating-Point” (20 points)**

Represent the following in single-precision IEEE floating point. Give your answers in *hexadecimal*. Enter the answers in the table below.

- a) -208.0
- b) 31.125
- c)  $(2^{18} - 1)$

<i>Decimal</i>	<i>Sign</i>	<i>Exponent (binary)</i>	<i>Significand (binary)</i>	<i>Complete Number (Hex)</i>
-208.0				
31.125				
$2^{18} - 1$				

Convert the following single-precision floating-point number (given in hexadecimal) to decimal, and enter the answer in the table below:

- d) 0x238c1000.

<i>Hex</i>	<i>Sign</i>	<i>Exponent (binary)</i>	<i>Significand (binary)</i>	<i>Decimal</i>
238c1000				

**Problem 5. “Floating-Point Arithmetic” (20 points)**

Given the following two single-precision IEEE floating-point numbers:

$$x = 0x35850000 \quad \text{and} \quad y = 0xabd10000$$

Compute the following in *binary or hexadecimal* showing all work:  $x + y$

NOTE: You must follow the floating-point addition algorithm presented in class. That is, handle exponents, mantissas, alignment, rounding, normalization, etc. as discussed in class. Do NOT simply convert these numbers into decimal and compute the answers using a calculator! Show the binary values at each step of the algorithm. Write your answer and show all work below.