

## DIGITAL COMPASS SOLUTIONS

### Features

- 1° Heading Accuracy, 0.1° Resolution
- 0.5° Repeatability
- ±60° Tilt Range (Pitch and Roll) for HMR3300
- Small Size (1.0" x 1.45" x 0.4"), Light Weight
- Compensation for Hard Iron Distortions, Ferrous Objects, Stray Fields
- 15Hz Response Time
- -40° to 85°C Operating Temperature Range
- 6 to 15 volt DC Single Supply Required

### General Description

The Honeywell HMR3200/HMR3300 are electronic compassing solutions for use in navigation and guidance systems. Honeywell's magnetoresistive sensors are utilized to provide the reliability and accuracy of these small, solid state compass designs. These compass solutions are easily integrated into systems using a UART or SPI interface in ASCII format.

The HMR3300 is a three-axis, tilt compensated compass that uses a two-axis accelerometer for enhanced performance up to a ±60° tilt range.

The HMR3200 is a two-axis compass. Performance is optimized in vertical or horizontal orientations.

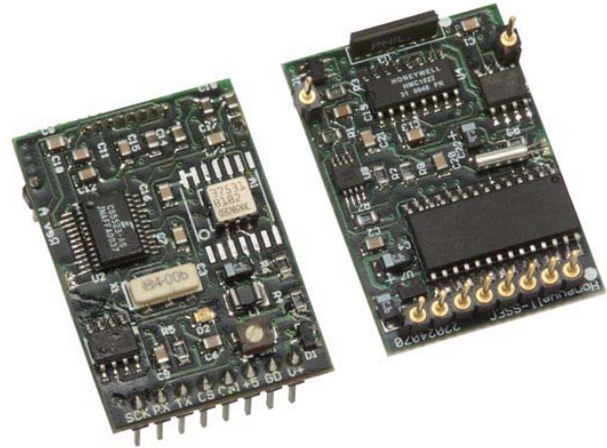

## APPLICATIONS

- **Compassing & Navigation**
- **Attitude Reference**
- **Satellite Antenna Positioning**
- **Platform Leveling**
- **GPS Integration**
- **Laser Range Finders**

Block Diagram

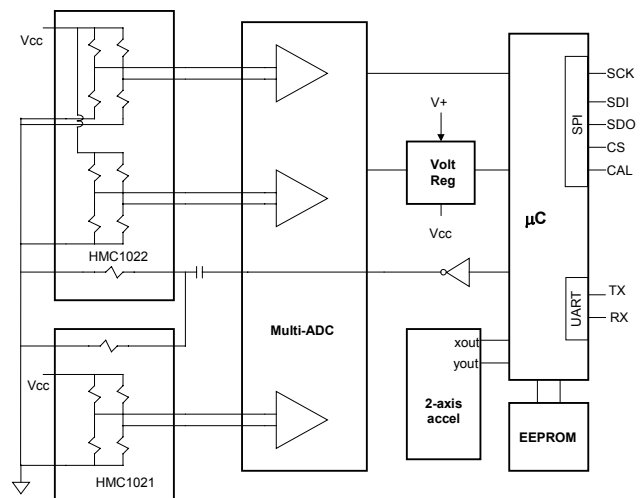

Web Site: [www.magneticsensors.com](http://www.magneticsensors.com)  
Email: [ssec.customer.service@honeywell.com](mailto:ssec.customer.service@honeywell.com)

# HMR3200/HMR3300

**Honeywell**

Preliminary

SENSOR PRODUCTS

**SPECIFICATIONS**

Characteristics	Conditions	Min	Typ	Max	Units
-----------------	------------	-----	-----	-----	-------

**Heading**

Accuracy	Level		1.0		deg RMS
	0° to ±30° (HMR3300 only)		1.5		
	±30° to ±60° (HMR3300 only)		3.0		
Resolution			0.1		deg
Hysteresis	HMR3200		0.1	0.2	deg
	HMR3300		0.2	0.4	
Repeatability	HMR3200		0.1	0.2	deg
	HMR3300		0.2	0.4	

**Pitch and Roll (HMR3300 only)**

Range	Roll and Pitch Range		± 60		deg
Accuracy	0° to ± 30°		0.4	0.5	deg
	± 30° to ± 60°		1.0	1.2	
Resolution			0.1		deg
Hysteresis			0.2		deg
Repeatability			0.2		deg

**Magnetic Field**

Range	Maximum Magnetic Flux Density		± 2		gauss
Resolution			0.1		milli-gauss

**Electrical**

Input Voltage	Unregulated	6	-	15	volts DC
Current	Active Mode HMR3200		18	20	mA
	Active Mode HMR3300		22	24	

**Digital Interface**

UART	ASCII (1 Start, 8 Data, 1 Stop, 0 Parity) User Selectable Baud Rate	2400	-	19200	Baud
SPI	CKE = 0, CKP = 0 Psuedo Master				
Update	Continuous/Strobed/Averaged				Hz
	HMR3200		15		
	HMR3300		8		
Connector	In-Line 8-Pin Block (0.1" spacing)				

**Physical**

Dimensions	Circuit Board Assembly		25.4 x 36.8 x		mm
			1.1		
Weight	HMR3200		7.25		grams

Web Site: [www.magneticsensors.com](http://www.magneticsensors.com)  
Email: [ssec.customer.service@honeywell.com](mailto:ssec.customer.service@honeywell.com)

2001 HMR3200/HMR3300 Published Sep 2001 Page 2

Honeywell  
Solid State Electronics Center  
12001 State Highway 55  
Plymouth, Minnesota 55441-4799  
1-800-323-8295

Preliminary

SENSOR PRODUCTS

Characteristics	Conditions	Min	Typ	Max	Units
	HMR3300		7.5		

**Environment**

Temperature	Operating	-40	-	+85	°C
	Storage	-55	-	+125	°C

## Pin Configuration

Pin Number	Pin Name	Description
1	SCK	Serial Clock Output for SPI Mode
2	RX/SDI	UART Receive Data/SPI Data Input
3	TX/SDO	UART Transmit Data/SPI Data Output
4	CS	Chip Select for SPI Mode
5	CAL	Calibration Input
6	+5VDC	Optional +5 VDC Power Input
7	GND	Power and Signal Ground
8	+V	Unregulated Power Input (+6 to +15 VDC)

This circuit board is approximately 1.45x1 inches with an 8-pin header. Hold the board with pin header edge close to you and pins pointing DOWN. Then PIN 1 is the left most pin.

## Application Notes

### SPI Timing Diagram

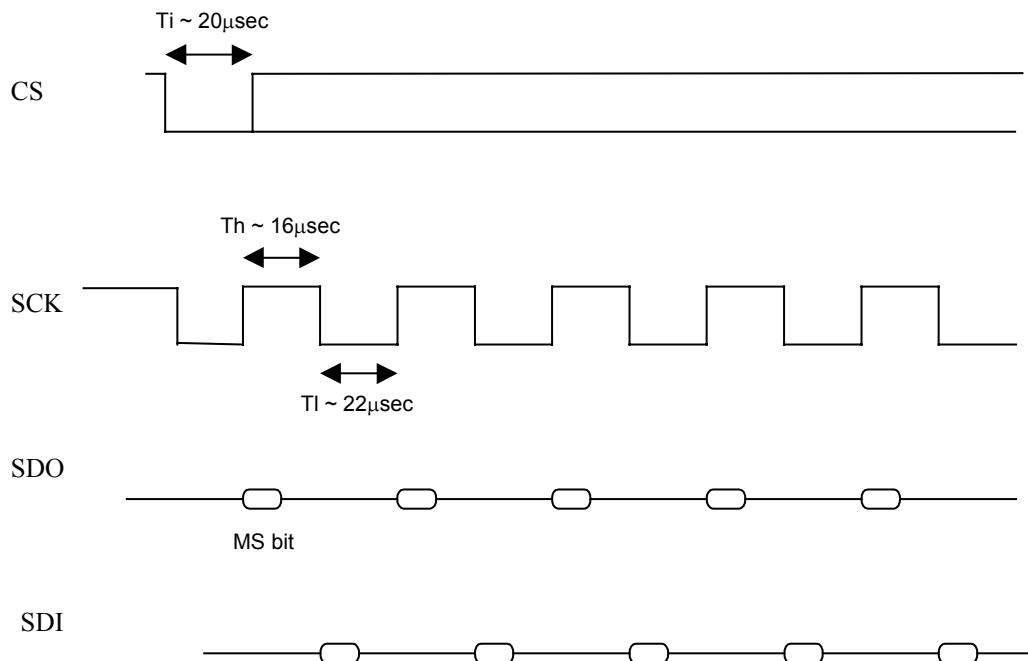

The HMR3200/HMR3300 modules communicate through ASCII characters at baud rate of 19200. The data format is 1 Start, 8 Data, 1 Stop, and No parity bits. Some of the operating commands are:

- |                             |                               |   |
|-----------------------------|-------------------------------|---|
| Heading Output Command      | <b>*H&lt;cr&gt;&lt;lf&gt;</b> | Selects the Heading output mode<br>Format: Heading, Pitch, Roll in degrees arc<br>Example: 235.6, 0.1, -0.3 |
| Magnetometer Output Command | <b>*M&lt;cr&gt;&lt;lf&gt;</b> | Selects the magnetometer output mode.<br>Format: MagX, MagY, MagZ<br>Eg: 1256, -234, 1894                   |

### SPI Interface – Operating Mode

SPI operating Mode is as follows:

- SCK idles low
- Data Output after falling edge of SCK
- Data sampled before rising edge of SCK
- (MODE CKP=0, CKE=0)

### SPI Communication Protocol

The HMR3200/HMR3300 module controls the SCK and SDO pins and the host controller controls SDI and CS pins. The host controller shall lower the HMR module's CS pin for at least 20 microseconds to initiate the SPI communication. In response the HMR module will send the ASCII bit pattern for 's', and the host shall transmit a valid command character simultaneously. The HMR module will evaluate the command character received from the host controller and send the appropriate data if the command is recognized and valid. After transmitting the required data, the HMR module will end the SPI session. If the command is invalid or was not recognized, then the HMR module will transmit ASCII bit pattern for 'e' and end the SPI session.

### SPI Commands

Heading Output: In response to an H or h command, the HMR3200/HMR3300 shall send two bytes of data. The MSByte is transmitted first. These two bytes represent the integer value equal to 10\*Heading. The MSbit is transmitted first for each byte. SCK shall be high for 16, and low for 22 microseconds, respectively. There is a 50 microsecond delay between consecutive bytes transmitted.

### Demonstration PCB Module Kit

The HMR3200/HMR3300 Demo Module its includes additional hardware and Windows software to form a development kit for electronic compassing. This kit includes the appropriate HMR3200 or HMR3300 Printed Circuit Board (PCB) module, an RS-232 motherboard with serial port connector, serial port cable with attached AC adapter power supply, interface software, and documentation.

### Ordering Information

Ordering Number	Product
HMR3200 HMR3200-Demo-232	PCB Module Only PCB Module with Development Kit
HMR3300 HMR3300-Demo-232	PCB Module Only PCB Module with Development Kit

Honeywell reserves the right to make changes to improve reliability, function or design. Honeywell does not assume any liability arising out of the application or use of any product or circuit described herein; neither does it convey any license under its patent rights nor the rights of others.

Web Site: [www.magneticsensors.com](http://www.magneticsensors.com)  
Email: [sssec.customer.service@honeywell.com](mailto:sssec.customer.service@honeywell.com)